



Stretch Wrapper
CTT 210



Stretch Wrapper CTT 210

Wraps irregular shaped loads. Uses forklift/palletjack to load stretch wrapper. Operator starts wrap cycle at machine. Operator manually cuts/attaches film.

These properties guarantee not only good load securement but also minimum material costs, i.e. low film consumption. With the CTT 210 you have the possibility to regulate the application of tension (force of applying the film to the product).



Standard machine specification and dimensions

Machine	Table diam	Ø1650 mm
	Speed	Up to 12 rpm adjustable
	Start / stop	Frequency controlled
	Bottom/ top wraps	1–7 (Prog 3, 2-14)
	Film carriage speed	Variable speed
	Pre-stretch system	ECOSTRETCH®
	Pre-stretch ratio	80, 145 or 233 % adjustable
	Stretch wrapping programs	5 standard, 1 option
	Controller	PLC
	Power	Supply
Protection		IP54
Loading		10 A
Pallet Goods	Max size (length x width)	1200 x 1000 mm
	Max. goods height incl. pallet:	2200 mm
	Permitted load weight	2000 Kg
Stretch Film	Core diameter	76 mm
	Outer diameter, max	250 mm
	Film width, max	500 mm
	Film thickness	9-35 my

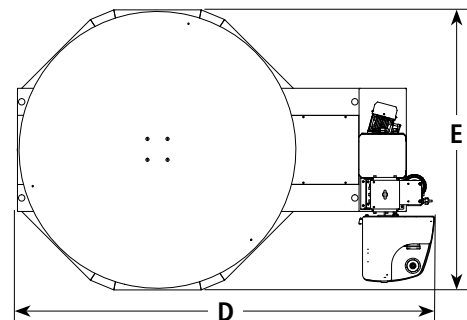
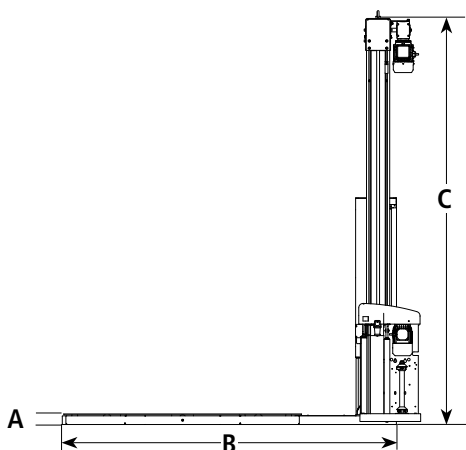

Dim (mm)	A	B	C	D	E
Standard	73	2305	2800	2475	1660

Weight, standard: 380 kg (Weight can vary depending on options). Crated dimensions: L2900 x H750 x W1700 mm, weight: 550 kg.

WWW.CYKLOPTEKNIK.SE

CYKLOP®
GLOBAL PACKAGING SOLUTIONS

STRAPPING
WRAPPING
CODING
TAPING